



Cessna
A Textron Company

Special Service Project

September 11, 2000

SSP00-57-01

TITLE

RIGHT WING SPAR CAP STIFFENER INSPECTION

EFFECTIVITY

The following airplanes delivered from Cessna with float plane provisions.

Model	Serial Numbers
206H	20608065 thru 20608068, 20608075, 20608079, 20608083, 20608085 thru 20608088 and 20608091
T206H	T20608101, T20608103 thru T20608108, T20608110, T20608112 thru T20608115, T20608117 thru T20608122, T20608124 thru T20608127, T20608133, T20608136 thru T20608139, T20608141, T20608143 thru T20608145, T20608150 thru T20608154, T20608157 and T20608158

REASON

Some right wings may have been manufactured with a spar cap stiffener made of 0.100 inch thick material instead of 0.125 inch thick material required for float plane operations.

DESCRIPTION

The right wing part number 1222005-12 Stiffener thickness shall be inspected. All airplane inspection results must be reported on the attached SSP00-57-01: Right Wing Spar Cap Stiffener Inspection Report form to Cessna Propeller Aircraft Product Support for further disposition.

COMPLIANCE

Mandatory; shall be inspected at the next scheduled inspection or 3 months or prior to the installation of floats, whichever occurs first.

APPROVAL

FAA approval has been obtained on technical data in this publication that affects airplane type design.

Page 1 of 5

To obtain satisfactory results, procedures specified in this publication must be accomplished in accordance with accepted methods and prevailing government regulations. Cessna Aircraft Company cannot be responsible for the quality of work performed in accomplishing the requirements of this publication.

Cessna Aircraft Company, Product Support, P.O. Box 7706, Wichita, Kansas 67277, U.S.A. (316) 517-5800, Facsimile (316) 942-9006

COPYRIGHT © 2000

MANPOWER

1.2 man-hours per airplane for inspection.

REFERENCES

Model 206H/T206H Series 1998 And On Maintenance Manual

Single Engine Models 172, 182, 206 and T206 1996 And On Structural Repair Manual

NOTE: Ensure all publications used are complete and current.

NOTE: This information shall be considered an amendment to the Cessna Manufacturer's Maintenance Manual or Instructions for continued airworthiness, and must be accomplished for ongoing airworthiness compliance as required per FAR43.13.

OTHER PUBLICATIONS AFFECTED

Model 206H And Model T206H Illustrated Parts Catalog

NOTE: Ensure all publications used are complete and current.

MATERIAL PRICE AND AVAILABILITY

Not applicable

CREDIT INFORMATION

A labor allowance credit of 1.2 man-hours per airplane will be provided for inspection of the right wing spar cap stiffener in accordance with this Special Service Project.

To receive credit, the work must be completed and a Quick Claim submitted by a Cessna Single Engine Service Station before the dates shown below. A copy of the SSP00-57-01: Right Wing Spar Cap Stiffener Inspection Report form and logbook entry showing compliance with SSP00-57-01 must accompany the Quick Claim.

Domestic	December 11, 2000
International	December 11, 2000

ACCOMPLISHMENT INSTRUCTIONS

1. Ensure that all switches are in the OFF position and disconnect electrical power from the airplane by disconnecting the battery and external electrical power. Attach maintenance warning tags to the battery and external power receptacle stating: **DO NOT CONNECT ELECTRICAL POWER - MAINTENANCE IN PROGRESS.**
2. Inspect the right wing spar cap to determine the thickness of the 1222005-12 Stiffener as follows:
 - A. Fabricate a 0.125 inch thick aluminum feeler gauge that is approximately 1.00 inch wide and 2.0 inches long.
 - B. Remove the 620AB Aileron Bellcrank Access Plate. (Refer to the Model 206H/T206H Maintenance Manual, Chapter 6, Dimensions and Areas.)
 - C. (Refer to Figure 1, Sheet 1, Detail A) Locate the end of the 1222005-12 Stiffener by looking up through the aileron bellcrank access hole.
 - D. Position the fabricated feeler gauge against the outboard end of the 1222005-12 stiffener. Maintain a small gap between the forward end of the gauge and the spar web to assure that the gauge does not ride in the bend radius between the flange and web of the spar channel.
 - E. With the feeler gauge flat up against the spar upper flange, compare thickness of gauge and stiffener by placing a finger over the intersection of both parts. The stiffener should be the same thickness as the gauge.

NOTE: A stiffener that is 0.025 inch thinner than the gauge may have been installed.

- (1) If the stiffener is the same thickness as the feeler gauge:
 - (a) Install the 620AB access plate. (Refer to the Model 206H/T206H Maintenance Manual, Chapter 6, Dimensions and Areas.)
 - (b) Reconnect battery and remove maintenance warning tags.
 - (c) Fill out and return the attached SSP00-57-01: Right Wing Spar Cap Stiffener Inspection Report form to Cessna Propeller Aircraft Product Support.
 - (d) Make an entry in the airplane logbook stating compliance with this Special Service Project. Logbook entry shall include the results of the inspection.
- (2) If the stiffener is thinner than the 0.125 inch feeler gauge, further disposition will be coordinated through Cessna Propeller Aircraft Product Support.
 - (a) Install the 620AB access plate. (Refer to the Model 206H/T206H Maintenance Manual, Chapter 6, Dimensions and Areas.)
 - (b) Reconnect battery and remove maintenance warning tags.
 - (c) Fill out and return the attached SSP00-57-01: Right Wing Spar Cap Stiffener Inspection Report form to Cessna Propeller Aircraft Product Support.
 - (d) Make an entry in the airplane logbook stating compliance with this Special Service Project. Logbook entry shall include the results of the inspection.

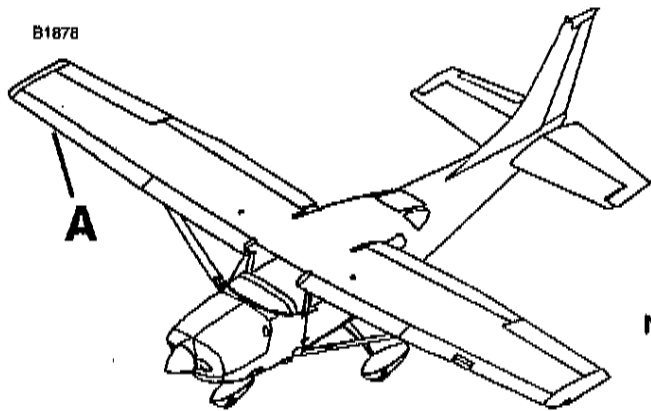

NOTE: PLACE THE FABRICATED (0.125 INCH THICK) ALUMINUM GAGE AGAINST THE END OF THE 1222005-12 STIFFENER AND COMPARE.

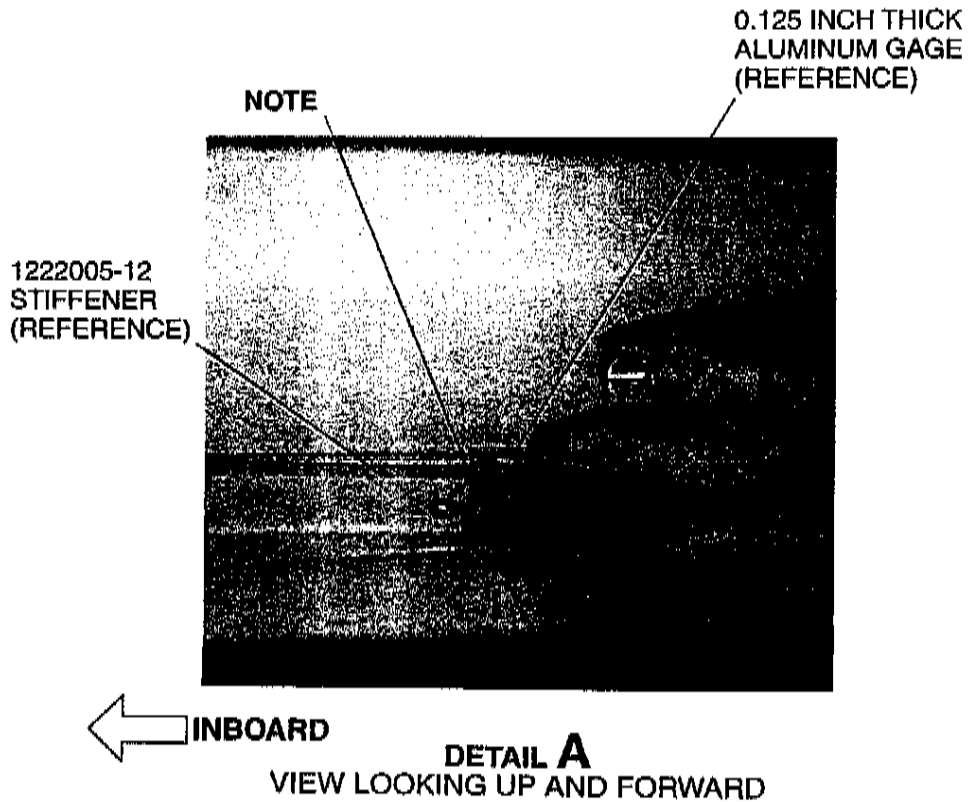

Figure 1. Wing Spar Inspection (Sheet 1)

OWNER NOTIFICATION

On September 11, 2000 a copy of this Special Service Project will be sent to applicable owners of record.

It is recommended that owners contact a Cessna Single Engine Service Station for detailed information and arrange to have Special Service Project SSP00-57-01 accomplished on their airplane.

* * * * *

!



SSP00-57-01: Right Wing Spar Cap Stiffener Inspection Report

To: Cessna Aircraft Company
Propeller Aircraft Product Support
P. O. Box 7706
Wichita, Kansas 67277-7706
Phone Number: (316) 517-5800
Fax Number: (316) 942-9006
E-mail: srbrooks@cessna.textron.com

Page: 1 of ___ Pages
Includes this cover sheet

Model 206H: _____	T206H: _____	Total Time In Service (Hrs.): _____
Serial Number: _____		Registration No.: _____
Operator Name: _____		Maintenance Facility Name: _____
Address: _____		Address: _____
_____		_____
FAA Registered Owner: _____		_____
Address: _____		_____
_____		Repair Station Number: _____
_____		Work Order Number: _____
_____		Phone Number: _____
Phone Number: _____		Fax Number: _____
Fax Number: _____		_____

Please complete the following information regarding this Special Service Project and fax this form to Cessna Propeller Aircraft Product Support as soon as possible.

1. What is the spar cap stiffener thickness? _____

CERTIFICATION OF COMPLIANCE

SSP00-57-XX: Right Wing Spar Cap Stiffener Inspection complete: _____

Date of Compliance: Month _____ Day _____ Year _____

Mechanic/Inspector Name: _____

Certificate Number: _____

Signature: _____